

DATASHEET

RAYMARK: RM-SFP10G-LR1

10Gb/s SFP+ LR Transceiver

Overview

Raymark RM-SFP10G-LR1 SFP+ optical transceivers are based on 10G Ethernet IEEE 802.3ae standard and SFF-8431 standard, providing a fast and reliable interface for 10G Ethernet applications. The product implements digital diagnostics via a 2-wire serial bus, compliant with the SFF-8472 standard.

Product Features

- Supports from 9.83Gb/s to 11.3Gb/s bit rates
- Compliant with IEEE 802.3ae 10GBASE-LR/LW
- Compliant with 10G FC 1200-SM-LL-L
- Compliant with SFF-8431
- Hot-pluggable SFP+ footprint
- 1310nm DFB laser transmitter
- Duplex LC connector
- Built-in digital diagnostic functions
- Up to 10km on SMF
- Single power supply 3.3V
- RoHS Compliant
- Operating temperature range (Case Temperature): Commercial Level: 0°C to 70°C

Applications

- 10GBASE-LR/LW Ethernet
- 10G Fibre Channel
- 10G CPRI

Ordering Information

Part Number	Description	Color on Clasp
RM-SFP10G-LR1	10GBASE-LR SFP+ 1310nm LC Connectors 10km on SMF, Commercial Temperature.	Blue

General Specifications

Parameter	Symbol	Min	Typ	Max	Unit	Remarks
Data Rate	DR	9.83	10.3125	11.3	Gb/s	1
Bit Error Rate	BER			10^{-12}		
Operating Temperature	T _c	0		70	°C	2
Storage Temperature	T _{sto}	-40		85	°C	3
Supply Current (Commercial Temperature)	I _{cc}		200	310	mA	4
Supply Current (Industrial Temperature)	I _{cc}		200	350	mA	4
Input Voltage	V _{cc}	3.14	3.3	3.46	V	
Power Dissipation (Commercial Temperature)	P _c		0.65	1.0	W	
Power Dissipation (Industrial Temperature)	P _i		0.65	1.2	W	
Maximum Voltage	V _{MAX}	-0.5		4	V	4

Notes:

1. IEEE 802.3ae
2. Case temperature
3. Ambient temperature
4. For electrical power interface

Link Distances

Data Rate	Fiber Type	Distance Range (km)
9.83 -11.3 Gb/s	9/125umSMF	10

Optical - Characteristics - Transmitter

V_{CC}=3.14V to 3.46V, T_c

Parameter	Symbol	Min	Typ	Max	Unit	Remarks
Output Optical Power	P _{TX}	-8.2		0.5	dBm	1
Optical Center Wavelength	λ _c	1260		1355	nm	
Optical Modulation Amplitude	OMA	-5.2			dBm	2
Extinction Ratio	ER	3.5	5.5		dB	
Spectral Width(-20dB)	Δλ			1	nm	
Side Mode Suppression Ratio	SMSR	30			dB	
Relative Intensity Noise	RIN			-128	dB/Hz	
Transmitter Dispersion Penalty	TDP			3.2	dB	
Launch Power of OFF Transmitter	P _{OUT_OFF}			-30	dBm	1
Transmitter Jitter						2

Notes:

1. Average
2. According to IEEE 802.3ae requirement

Optical - Characteristics - Receiver

V_{CC}=3.14V to 3.46V, T_c

Parameter	Symbol	Min	Typ	Max	Unit	Remarks
Optical Center Wavelength	λ _c	1260		1600	nm	
Average Receive Power	P _{RX}	-14.4		0.5	dBm	
Receiver Sensitivity @10.3Gb/s	R _{X_SEN}			-14.4	dBm	1
Receiver Reflectance	T _{R_RX}			-12	dB	
LOS Assert	LOS _A	-30			dBm	
LOS De-Assert	LOS _D			-17	dBm	
LOS Hysteresis	LOS _H	0.5			dB	

Notes:

1. Test the resulting value using the minimum ER value within the defined range; BER<10⁻¹²; 2³¹-1 PRBS

Electrical - Characteristics - Transmitter

V_{CC}=3.14V to 3.46V, T_c

Parameter	Symbol	Min	Typ	Max	Unit	Remarks
Input differential impedance	R _{IN}		100		Ω	
Differential data input swing	V _{IN_PP}	180		700	mV	
Transmit disable voltage	V _D	2		V _{CC}	V	
Transmit enable voltage	V _{EN}	V _{EE}		V _{EE} +0.8	V	

Electrical - Characteristics - Receiver

V_{CC}=3.14V to 3.46V, T_c

Parameter	Symbol	Min	Typ	Max	Unit	Remarks
Differential data output swing	V _{OUT_PP}	300		850	mV	
Data output rise/fall time (20%-80%)	t _r /t _f	28			ps	
LOS Assert	V _{LOS_A}	2		V _{CC_HOST}	V	
LOS De-Assert	V _{LOS_D}	V _{EE}		V _{EE} +0.5	V	

DDM Threshold Information

Parameter	Alarm Threshold		Warning Threshold	
	High Value	Low Value	High Value	Low Value
Temperature (°C)	90 (5A 00)	-10 (F6 00)	85 (55 00)	-5 (FB 00)
V _{CC} (V)	3.63(8D CC)	2.97 (74 04)	3.46 (87 28)	3.13 (7A 44)
Bias (mA)	100 (C3 50)	2 (03 E8)	80 (9C 40)	4 (07 D0)
TxPower (dBm)	1.3 (34 98)	-9.2 (04 BA)	0.5 (2B D4)	-8.2 (05 E9)
RxPower (dBm)	3.0 (4E 20)	-18.0 (00 9E)	0.0 (27 10)	-15.0 (01 3C)

Product Weight

Net weight of module: 17.0g/pcs

Net weight of dust cap: 0.95g/pcs

Dimensions

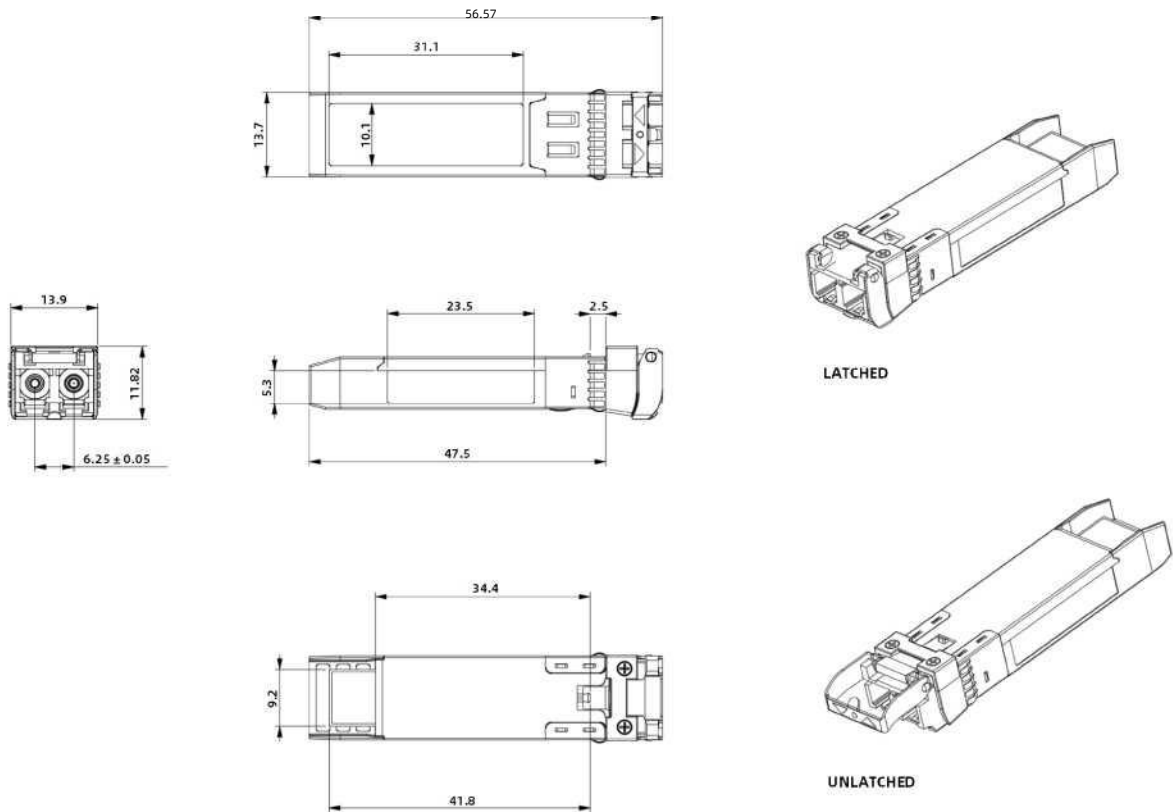

ALL DIMENSIONS ARE ±0.2mm UNLESS OTHERWISE SPECIFIED

Electrical Pad Layout

Top view

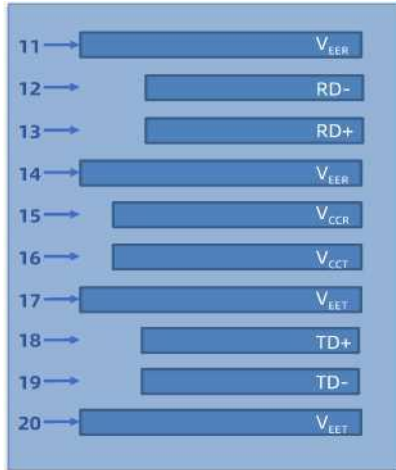

Bottom view

